

Feb. 20, 1968

T. LAMPERT

3,369,578

DISPENSING DEVICE

Filed Dec. 7, 1964

2 Sheets-Sheet 1

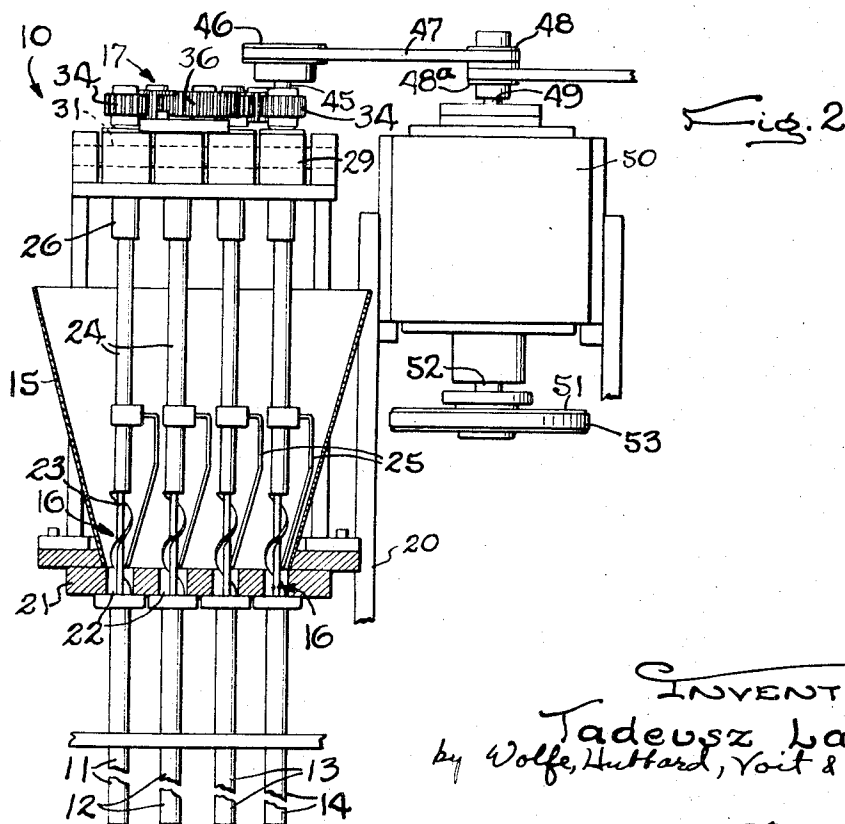
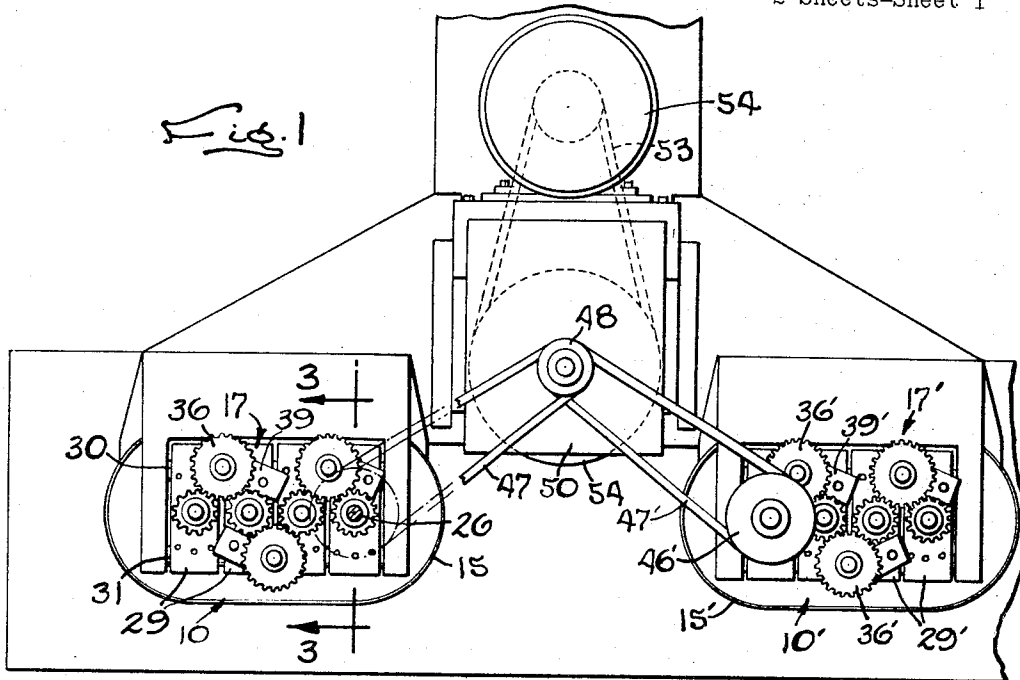

INVENTOR
Tadeusz Lampert
by Wolfe, Hultford, Yoit & Casanu

ATTORNEY

Feb. 20, 1968

T. LAMPERT

3,369,578

DISPENSING DEVICE

Filed Dec. 7, 1964

2 Sheets-Sheet 2

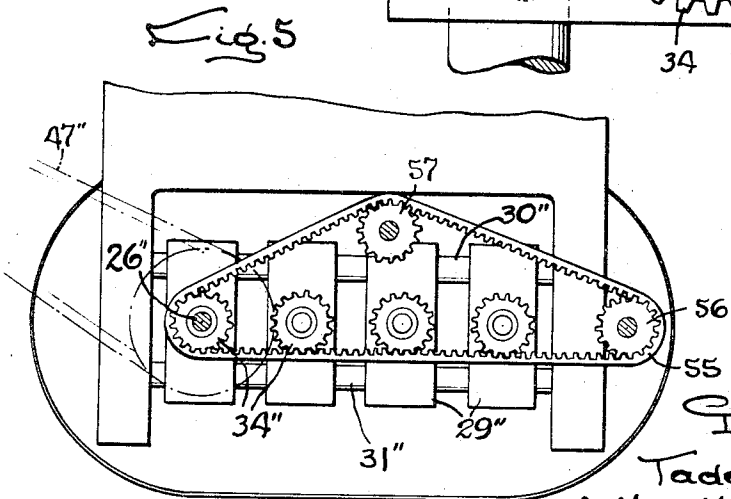
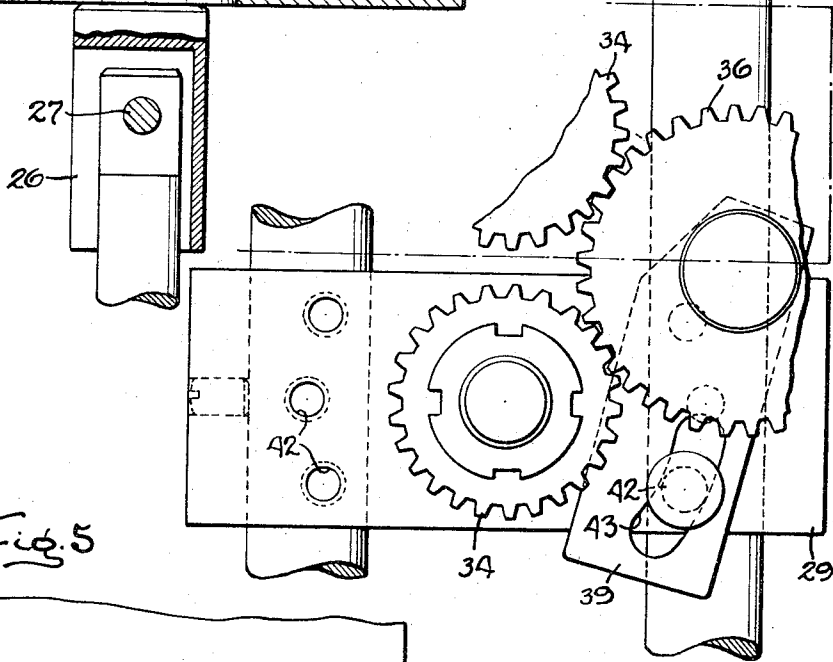
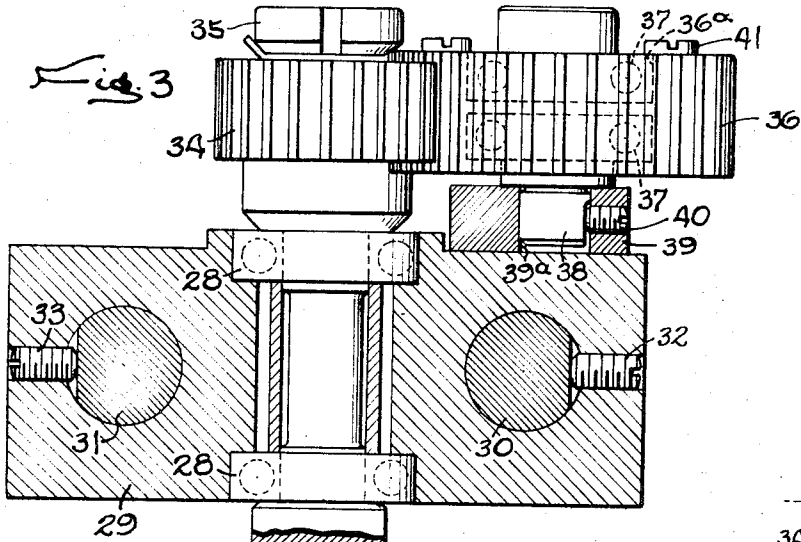

INVENTOR
Tadeusz Lampert
15" by Wolfe, Hubbard, Yait & Osann
ATTORNEYS

1

3,369,578

DISPENSING DEVICE

Tadeusz Lampert, Rockford, Ill., assignor to Bartelt Engineering Company, Inc., Rockford, Ill., a corporation of Delaware

Filed Dec. 7, 1964, Ser. No. 416,481

4 Claims. (Cl. 141-235)

ABSTRACT OF THE DISCLOSURE

A plurality of spaced feed augers disposed within a hopper and selectively adjustable toward and away from each other to vary the spacing between the augers so that the latter may be alined with containers of different sizes and shapes to discharge a product from the hopper into the containers. A drive mechanism for rotating the augers is in driving engagement with the augers in all of their adjusted positions.

Background of the invention

This invention relates to a dispensing device for discharging a product into a container and, more particularly, to a dispensing device having a plurality of feed mechanisms in the form of spaced augers which are power rotated to discharge the product into a series of containers simultaneously.

Summary of the invention

In its primary aspect, the present invention contemplates a new and improved dispensing device of the above character in which the feed augers are adjustable toward and away from each other to vary the spacing between the augers so as to accommodate containers of different types. Provision is made of a novel drive mechanism which may be set into driving engagement with the augers regardless of the spacing selected thereby to rotate the augers in all of their adjusted positions.

Brief description of the drawings

FIGURE 1 is a top view of the feed mechanism.

FIG. 2 is a side view, partially in section, of the feed and fill mechanism.

FIG. 3 is a cross-sectional view along the line 3-3 of FIG. 1.

FIG. 4 is an enlarged partial view of the feed mechanism gears.

FIG. 5 is a top view of a second embodiment of the invention.

Detailed description

For purposes of illustration, the invention is shown in the drawings embodied in a dispensing and volumetric measuring device 10 including a plurality of elongated upright spouts 11, 12, 13 and 14 through which a product comprising articles or material is discharged. The product is stored in a hopper 15 and fed in measured quantity through a feed mechanism 16 associated with each spout. The feed mechanisms are driven by means of a driving assembly 17. In this embodiment, four spouts are associated with the hopper for simultaneously filling four bags or containers (not shown) placed beneath the spouts. The spouts 11, 12, 13 and 14 are supported in a vertical position from a support means comprising an upright frame 20 and a horizontal spout support 21. The support 21 also serves as a bottom wall of the hopper 15 and is connected detachably to the frame 20 by bolts 21a. Each spout alines with an opening 22 in the support 21 with an auger 23 extending from within the bin to the spout and supported for rotation by a shaft 24. When the augers are rotated for a predetermined length of time, a meas-

2

ured quantity of the product or material is carried to each spout to drop by gravity into a container. Agitators 25 attached to the shafts 24 assure a constant feeding of material to the augers.

Since the bags or containers may vary in size, it is advantageous to employ spouts of different spacing adapted to be alined with the different containers used thereby to provide a universal dispensing device, and to employ feed mechanisms that can be adjusted into alinement with variously spaced spouts and that can be driven in all of their adjusted positions. It is to this purpose that the present invention is directed in providing a driving assembly which remains in driving engagement with the feed mechanisms as the latter are adjusted into alinement with the spouts. In accordance with this element of the invention, the feed mechanisms 16 and associated shafts 24 are in driving engagement with the driving assembly 17 in a manner allowing movement of the feed mechanisms and shafts toward and away from each other to vary the spacing between the feed mechanisms thereby to accommodate differently spaced spouts. In FIGS. 1-4, the upper ends of shafts 24 are illustrated extending into shaft extensions 26 and fastened thereto by locking screws 27, with the shaft extensions being supported by bearings 28 held by bearing blocks 29 provided for each shaft. The blocks 29 are individually supported on bars 30 and 31 extending from the frame 20 such that the segmented blocks may be moved along the bars to vary the spacing between each individual feed mechanism. Locking screws 32 and 33 lock the blocks in position on the bars.

Driven members which herein are gears 34, are keyed to the upper end of each shaft extension 26 and held in position by a screw 35 threaded into the shaft extension. Interconnecting the driven gears 34 are driving members comprising connecting gears 36 spaced between and in driving engagement with each adjacent pair of driven gears and positioned alternately on each side of the driven gears to form a continuous gear chain of driven and connecting gears.

The connecting gears are supported for rotation on bearings 37 fitting into the recesses 36a in the gears. The bearings are mounted on pins 38 which extend into openings 39a in the gear plates 39 and are held therein by locking screws 40. Bolts 41 threaded into the gears hold the gears on the supporting bearings. Each gear plate 39 is mounted on a pin 42 threaded into a bearing block 29 by the pin extending through an arcuate shaped slot 43 in the gear plate such that the plate may pivot in a plane parallel to the block surface and may move toward and away from the pin somewhat since the slot is larger than the pin.

As the bearing blocks 29 are adjusted with respect to one another on the bars 30 and 31, the driven gears 34 are similarly adjusted. To maintain the connecting gears 36 in driving engagement with the adjacent gears 34, the gear plates 39 may be pivoted to move the connecting gears 36 into driving engagement with the driven gears in the adjusted positions of the latter. The pins 42 may be fitted into any of several spaced openings 43a in the bearing blocks for proper positioning of the gear plates and connecting gears so that the gears 36 may engage with and be positioned between the driven gears 34 regardless of their spacing.

Connecting with the right-hand shaft extension 26 is a shaft 45 illustrated in FIG. 2 to which is keyed a pulley 46 driven by a V-belt 47 extending from a pulley 48 supported on an output shaft 49 of the clutch 50. Another pulley 51 is keyed to an input shaft 52 of the clutch and driven by a V-belt 53 extending from a motor 54 for driving the filling mechanism. The clutch is similar to those generally employed allowing continuous rotation of the drive motor 54 and effecting an intermittent driving

connection between the motor and the driving assembly such that the feed mechanism is rotated a predetermined length of time for each filling sequence. Braking of the output shaft 49 may be done within the clutch to assure that the fill mechanism is driven a precise time or number of revolutions. A clutch of this general type is disclosed in Bartelt, U.S. Patent 2,737,278. As illustrated in the drawings, other pulleys 48a may be driven from the output shaft 49 of the clutch 50 to drive similar dispensing devices, with one such device illustrated having like mechanisms indicated by the prime numbers.

In operation, a set of four containers are positioned beneath the hopper 15 with the material to be packaged in these containers stored within the hopper. The feed mechanisms and supporting bearing blocks 29 are then moved along the bars 30 and 31 until each aligns with a container, with the connecting gears 36 and the gear plates 39 being moved to maintain driving engagement with the adjacent driven gears 34. An appropriate spout assembly comprising the fill spouts and spout support 21 having spouts 11, 12, 13 and 14 spaced from each other in accordance with the size and shape of the containers then is selected and is fastened to the frame 20 by the bolts 21a. The spouts and the holes 22 in the support 21 are telescoped over the lower ends of the feed mechanisms as an incident to attaching the support. With the feed mechanisms properly aligned with the selected spouts and with the containers in place, the motor 53 is started for continuous rotation. The clutch 50 is then engaged for a predetermined length of time for driving the mechanism 17 and rotating the augers 23 of the feed mechanisms 16 to carry a measured quantity of the product from the hopper to each spout to thereafter drop into the containers for packaging. These filled containers are then removed and others placed in position. Of course, the positions of the feed mechanisms 16 and driving mechanism 17 need only be changed and a different spout support 21 with differently spaced spouts need only be selected when the container spacing changes, as when containers of a different size or shape are to be filled.

In FIG. 5 is illustrated a second embodiment of the invention utilizing the bearing blocks 29'' supported on spaced support bars 30'' and 31'' as heretofore described. Gears or sprockets 34'' are supported from the shaft extensions 26'' and comprise the driven member. These gears are driven by a driving member comprising an interconnecting belt or chain 55 extending in driving engagement with each gear and around support gears 56 and 57. In this embodiment as the blocks 29'' are moved along the support bars 30'' and 31'' the gears 34'' move parallel to the drive belt 55 to remain in driving engagement with the drive belt. Of course, there is usually no need to adjust the extreme left-hand feeding mechanism or the left-hand gear 34'' since the other three mechanisms can be adjusted relative to the left-hand mechanism to accommodate different containers. As a result, the left-hand mechanism can be left in the position shown in FIG. 5 so that the belt 55 always will remain properly tensioned around the fixed gears 56 and 57 and the left-hand gear 34''. The clutch and motor for this embodiment may be the same as heretofore described.

While particular embodiments of the invention have been illustrated and described, it will be obvious to those skilled in the art that various changes and modifications may be made without departing from the invention, and it is intended to cover in the appended claims, all such changes and modifications that come within the true spirit and scope of the invention.

I claim:

1. In a dispenser for discharging a product, the combination of, a support, a hopper mounted on said support for holding a supply of product and having a discharge opening in its lower end, a plurality of spaced feed augers disposed in upright positions within said hopper and operable when rotated to deliver measured quantities of product in separate streams from the lower end of the hopper, means at the lower end of the hopper for confining the product in said streams and for preventing the flow of product from the lower end of the hopper between the augers, said augers having upper ends disposed above the level of the product in said hopper, means adjustably mounting the upper ends of said augers on said support for selective movement of the augers toward and away from each other thereby to vary the spacing between the augers, driven members fastened to and movable with said augers for rotating the latter, a drive mechanism disposed in driving engagement with said driven members in all adjusted positions of said augers, and a power actuator operable to drive said drive mechanism thereby to rotate said augers in unison through said drive mechanism and said driven members.

2. A dispenser as defined in claim 1 in which said driven members comprise driven gears fast on the upper ends of said augers and rotatable about spaced axes, and said drive mechanism comprises a set of connecting gears each disposed between an adjacent pair of driven gears and mounted on said support for movement toward and away from a line extending between the axes of rotation of the driven gears.

3. A dispenser as defined in claim 2 in which said connecting gears also are mounted for bodily movement with said augers as the latter are moved toward and away from each other.

4. A dispenser as defined in claim 1 in which said driven members comprise driven toothed elements fast on the upper ends of said augers, and said drive mechanism comprises an endless belt having a toothed run extending parallel to the direction of adjustment of said augers and disposed in driving engagement with said toothed elements to rotate said augers.

References Cited

UNITED STATES PATENTS

640,375	1/1900	Gebhardt	141—257	X
2,443,182	6/1948	Carter	141—234	X
2,718,993	9/1955	McKinnon	141—191	X
2,932,330	4/1960	Donofrio	141—242	X

LAVERNE D. GEIGER, *Primary Examiner*.

E. J. EARLS, *Assistant Examiner*.