

Jan. 26, 1960

C. B. HARKER

2,922,568

PACKAGE FOR TOBACCO OR THE LIKE

Filed March 1, 1954

2 Sheets-Sheet 1

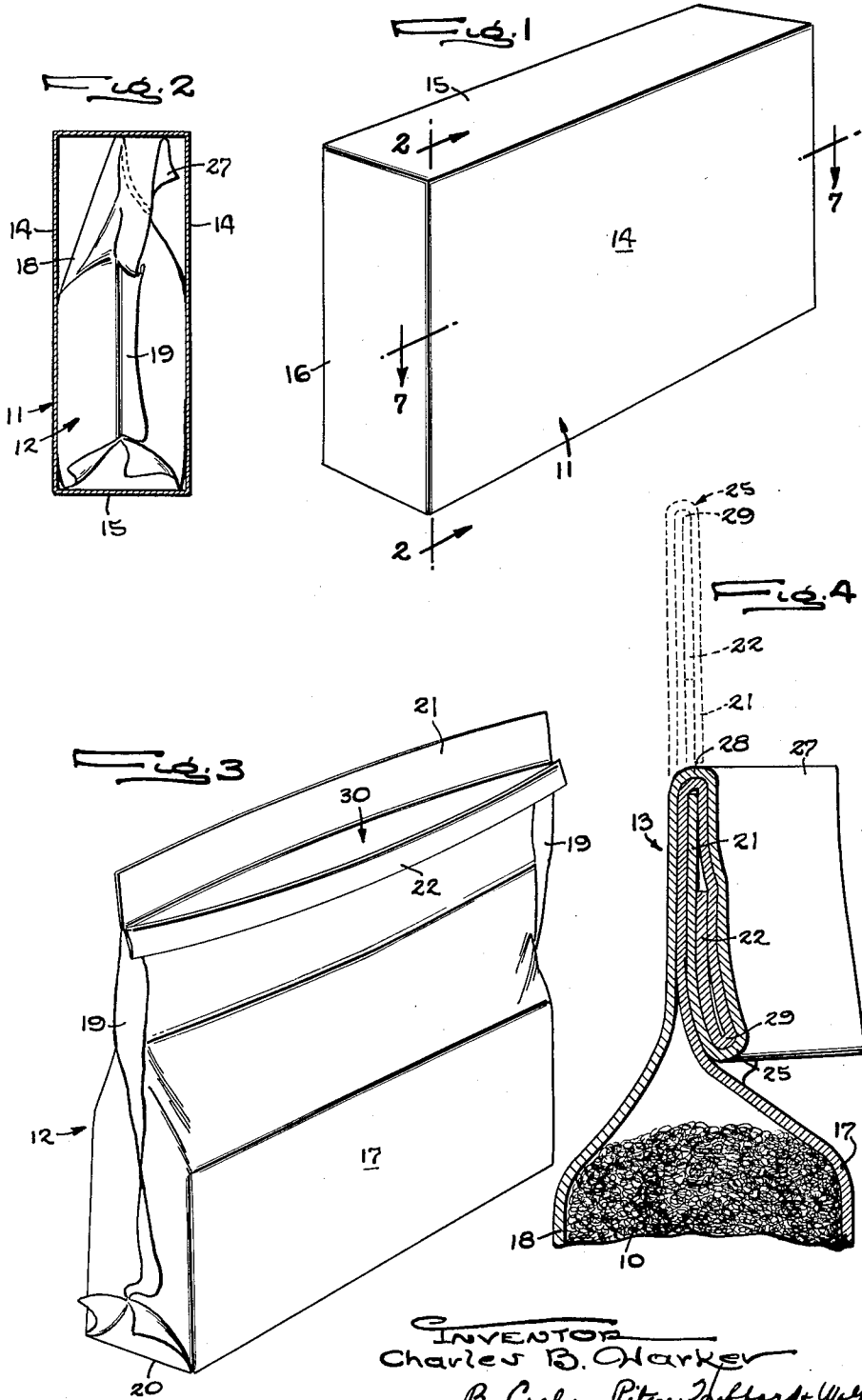

INVENTOR
Charles B. Harker
By Carlsm, Pitzner, Hubbard & Wolfe
ATTORNEYS

Jan. 26, 1960

C. B. HARKER

2,922,568

PACKAGE FOR TOBACCO OR THE LIKE

Filed March 1, 1954

2 Sheets-Sheet 2

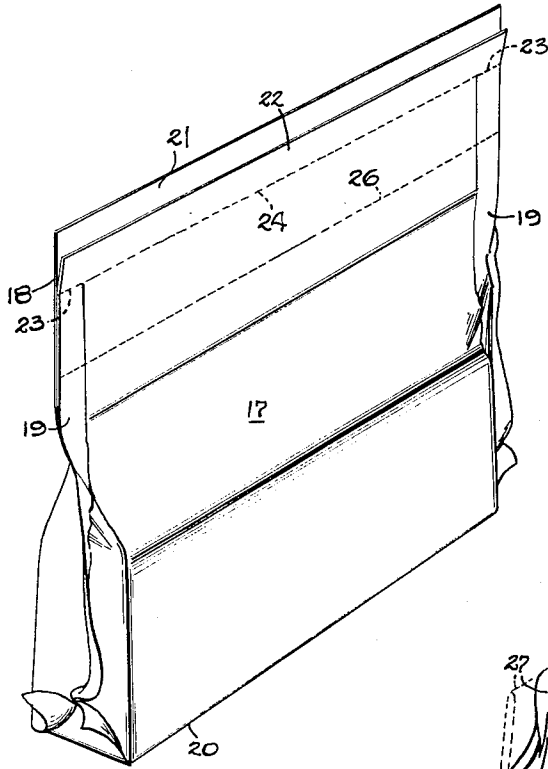

Fig. 5

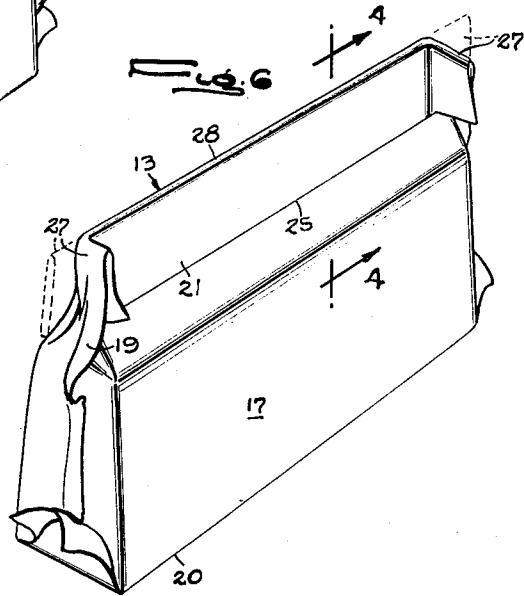

Fig. 6

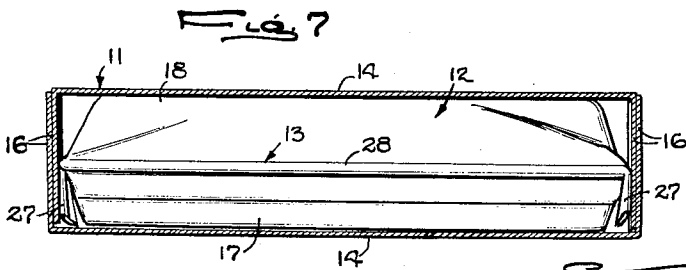

Fig. 7

INVENTOR
Charles B. Harker
By *Carlson, Pitzner, Hubbard & Wolfe*
ATTORNEYS

1

2

2,922,568

PACKAGE FOR TOBACCO OR THE LIKE

Charles B. Harker, Rockford, Ill., assignor to Bartelt Engineering Company, Rockford, Ill., a corporation of Illinois

Application March 1, 1954, Serial No. 413,399

3 Claims. (Cl. 229—62)

This invention relates to a pocket size package for storing loose material and including a box or carton and a pouch therein providing an air tight enclosure for a body of material such as tobacco.

The general object is to provide a package of the above character which, as compared to similar prior packages, possesses a longer shelf life, is more economical, better retains its air tightness after successive openings and closings in service use, and which may be formed on high speed packaging machinery.

A more detailed object is to achieve air tightness of the pouch by double folding of the open end thereof and to maintain the folded condition effectually and without adhesives by a novel coaction between the carton walls and parts of the fold.

Another object is to provide a novel pouch in which the entry of the user's fingers is facilitated by a novelly arranged folded edge which is left at the pouch opening when the double fold is opened.

Other objects and advantages of the invention will become apparent from the following detailed description taken in connection with the accompanying drawings, in which

Figure 1 is a perspective view of a completed package embodying the novel features of the present invention.

Fig. 2 is a section taken along the line 2—2 of Fig. 1.

Fig. 3 is a perspective view of the pouch after being opened in service use.

Fig. 4 is an enlarged cross sectional view taken along the line 4—4 of Fig. 6.

Fig. 5 is a perspective view of the filled pouch before closure thereof.

Fig. 6 is a similar perspective view of the closed pouch.

Fig. 7 is a section taken along the line 7—7 of Fig. 1.

The improved package in the form shown in the drawings for purposes of illustration is especially useful for containing and protecting a quantity 10 of loose material such as tobacco and comprises generally a relatively rigid cardboard box or carton 11 housing a pouch or bag 12 of flexible material partially filled with the measured charge 10 and rolled over at its open end to provide a double fold 13. The latter provides an air tight closure even after being opened and closed repeatedly in service use by the pipe smoker.

The carton 11 is of pocket size and squared rectangular shape comprising side walls 14 joined by narrower edge walls 15 to form a tube. Flaps 16 (Fig. 7) integral with the ends of the side walls are bent into overlapping relation and adhesively secured together to form the end walls of the box after insertion of the pouch 12 therein.

The pouch comprises front and rear panels 17 and 18 of flexible heat sealable material such as aluminum foil coated with thermo plastic material on their opposed faces with the outer side margins thereof sealed together under heat and pressure to form side seals 19. The pocket thus defined between the panels may be formed from a single strip folded, as is well understood in the art to form a bellows-like bottom which, when the tobacco or

other material is introduced into the pocket expands and assumes a substantially square shape having a flat bottom 20.

At the open end of the pouch, the rear panel 18 is extended a short distance beyond the front panel 17 to form a flap 21. The outer end portion 22 of the shorter panel 17 forms a second similar flap and for this purpose the heat seals forming the side seams 19 terminate at 23 short of the free edge of the panel by an amount equal to the desired width of the flap 22.

The pouch construction as above described may be formed and filled automatically in a machine of the character shown in Patent No. 2,649,674. When filled, the pouch assumes the form shown in Fig. 5 with the upper portions of the panels lying flat against each other. To form the double fold 13 and close the pouch, the flaps 21 and 22 and the adjacent portions of the panels are bent forwardly along a line 24 connecting the upper ends 23 of the side seams. Then, the portion thus bent is turned reversely and downwardly against the outer surface of the panel 17 thus leaving a fold 25 (Fig. 4) at the upper end of the pouch. Next, the end portion at the top of the pouch is again bent forwardly along a line 26 and finally reversely until the fold 25 comes against the outer face of the panel 17 as shown in Figs. 4 and 6.

At this time, the width of the squared lower end portion of the pouch is substantially equal to the length of the carton 11 between the ends 16 but the flattened fold 13 is somewhat wider than the carton length. That is to say, the end portions 27 of the flattened fold 13 project outwardly beyond the flattened ends of the pouch bottom. To reduce the length of the fold, to conform to the width of the pouch bottom and provide for holding the fold closed, the end portions 27 are bent inwardly preferably through an angle of substantially 90 degrees so as to project forwardly from the fold and lie approximately in the planes of the ends of the squared bottom part of the pouch. The length of the fold is then substantially equal to the length of the carton.

In this final form of the pouch, the over-all dimensions conform to but are slightly smaller than the compartment so that the pouch may be received in the latter by endwise insertion through the open end of the carton. Upon full insertion to the final position shown in Fig. 7, one of the fold projections 27 will come against the bottom 16 of the carton and be held by the latter against outward bending. In a similar way, the end wall formed by the overlapping flap 16 as sealed together to close the other end of the carton lies adjacent the other one of the projections 27. Thus, after insertion of the pouch in the carton and closure of the ends of the latter, the ends 27 of the double fold are, by coaction with the carton walls 16, held against outward bending of the double fold 13. As a result, the latter is maintained flat against the panel 17 throughout the shelf life of the package. The pouch thus remains tightly sealed and the contents thereof protected.

After opening of the carton and removal of the pouch, the user may open the latter by inserting his thumb between the panel 17 and the fold 25 and then bending the latter outwardly and upwardly to straighten out the second fold 28 the parts then being positioned as shown in phantom in Fig. 4. Next, the thumb is inserted between the panel 17 and the free edge of the flap 21 to raise the latter and straighten out the first fold 25 without bending the flap 22 away from the panel 17. This flap thus remains turned downwardly as shown in Fig. 3 thereby leaving a folded over edge 29 at the upper end of the panel 17. This facilitates insertion of one's finger to separate the panels and form an opening 30

3

through which a pipe or the like may be inserted to remove the contents of the pouch.

Once the double folds 25 and 28 have been formed, creases along the lines of folding remain when the pouch is opened as shown in Fig. 3. It is easy then to reclose the pouch by manually folding the top portion over and over and downwardly along the creases previously formed. After bending the ends 27 inwardly to lock the double fold closed as shown in Fig. 6, the pouch will remain closed effectually while being carried about in the smoker's pocket. Such opening and closing of the pouch may be repeated numerous times without detracting from the air tightness of the seal formed by the double fold. The latter, it will be observed, is formed simply by double bending of the pouch panels and without the necessity of using tacky adhesive to which the contents would adhere and prevent effective reclosure of the pouch.

I claim as my invention:

1. The combination of, a bag of flexible heat sealable material comprising two opposed side panels, one projecting a short distance beyond the end of the other whereby to form a flap, and heat seals joining said panels along their side margins and forming side seams which terminate short of the top of said short panel whereby the unsealed end portion of said short panel forms a second flap, said flaps and the adjacent portions of said panels being bent reversely substantially along a transverse line joining the ends of said seams to fold said flaps flat against the outer surface of said short panel while permitting independent unfolding of said first flap to leave the shorter flap lying against said short panel.

2. An air tight package comprising a generally rectangular carton having spaced walls joined by narrower walls, a pouch in said carton composed of two panels of flexible material heat sealed together along their side margins and joined along their lower edges by a folded portion which forms an expanded bottom, and a body of loose material compacted into the bottom portion of said pouch and expanding the same to a squared shape

4

filling one end of said carton, the upper end portion of said pouch being flattened and folded over and over to form a substantially flat double fold constituting a seal with said double fold being disposed wholly above said material and lying in a generally vertical plane, the end portions of said double fold being turned inwardly substantially at right angles to the plane of said double fold and lying adjacent said narrower walls so as to be held thereby against outward bending whereby to prevent unfolding of said seal.

3. An air tight package comprising a pouch composed of flexible panels heat sealed together along their side margins and joined along their lower edges by a folded portion which forms an expanded bottom, a body of loose material compacted in said bottom, the upper end portion of said pouch being flattened and folded over and over to form a double fold with said double fold being disposed wholly above said material and lying in a generally vertical plane, the end portions of said double fold being bent inwardly at least through a right angle relative to said plane, and an enclosure receiving said pouch and having a wall coating with said end portions to hold the latter bent and thereby to maintain the straightened condition of said fold.

References Cited in the file of this patent

UNITED STATES PATENTS

917,124	Peirson	Apr. 6, 1909
954,034	Kohout	Apr. 5, 1910
2,020,804	Segal	Nov. 12, 1935
2,274,934	Piazzè	Mar. 3, 1942
2,296,895	Bergstein	Sept. 29, 1942
2,304,591	Pape et al.	Dec. 8, 1942
2,307,559	Angus	Jan. 5, 1943
2,597,305	Doyle	May 20, 1952
2,643,049	Bartelt	June 23, 1953

FOREIGN PATENTS

552,804	Great Britain	Apr. 27, 1943
---------	---------------	---------------