

Sept. 11, 1956

C. B. HARKER

2,762,273

FOLDING AND GUIDING MECHANISM FOR DOUBLE WALL BAG MACHINES

Filed Nov. 26, 1952

3 Sheets-Sheet 1

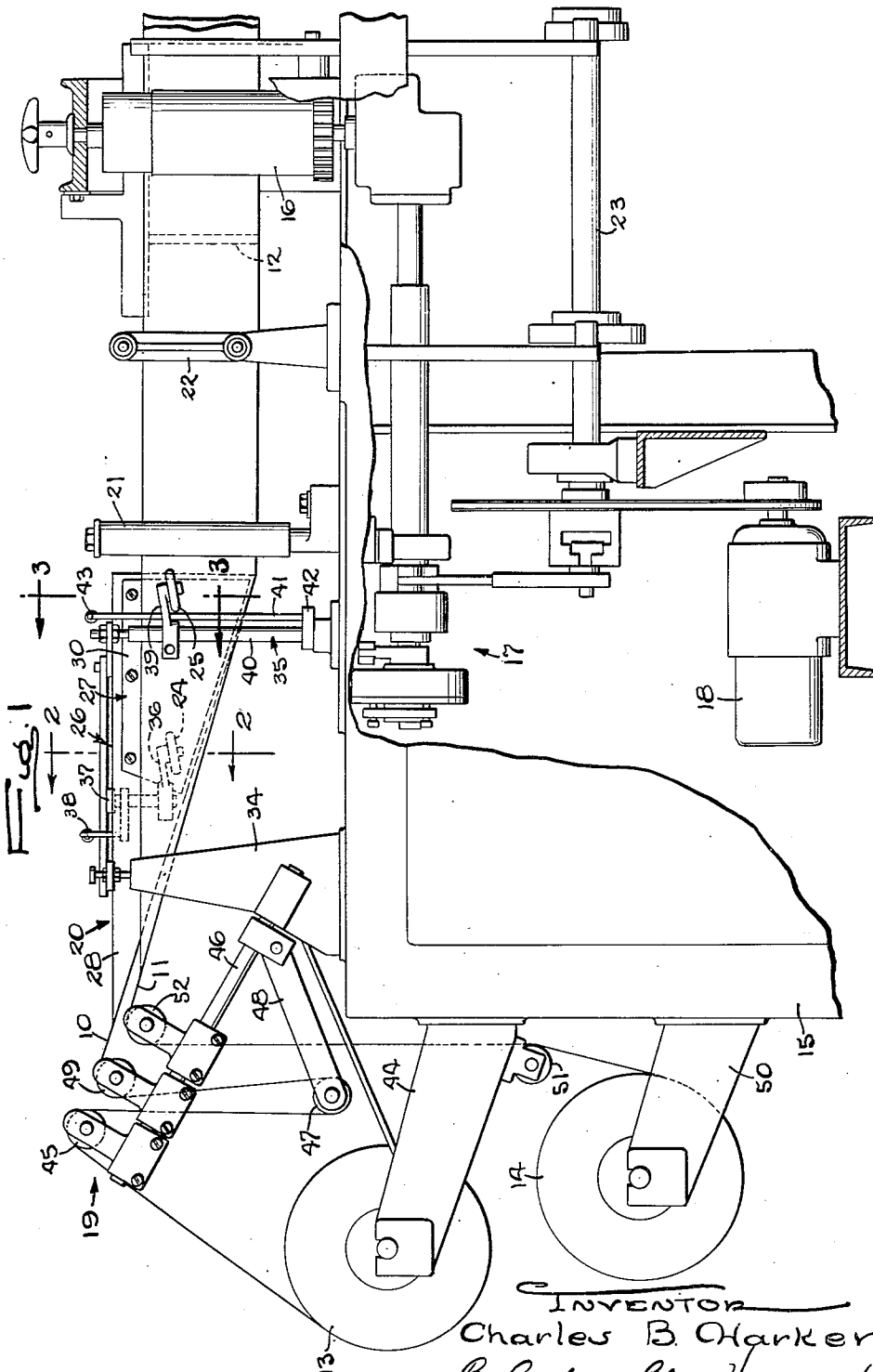

INVENTOR

Charles B. Harker

By *Carlson, Piquet, Hultman & Wolfe*
ATTORNEYS

Sept. 11, 1956

C. B. HARKER

2,762,273

FOLDING AND GUIDING MECHANISM FOR DOUBLE WALL BAG MACHINES

Filed Nov. 26, 1952

3 Sheets-Sheet 2

FIG. 2

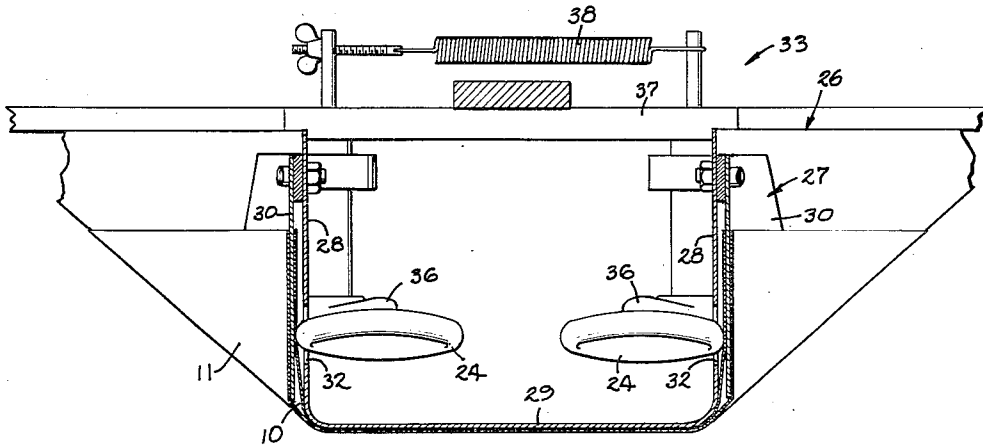
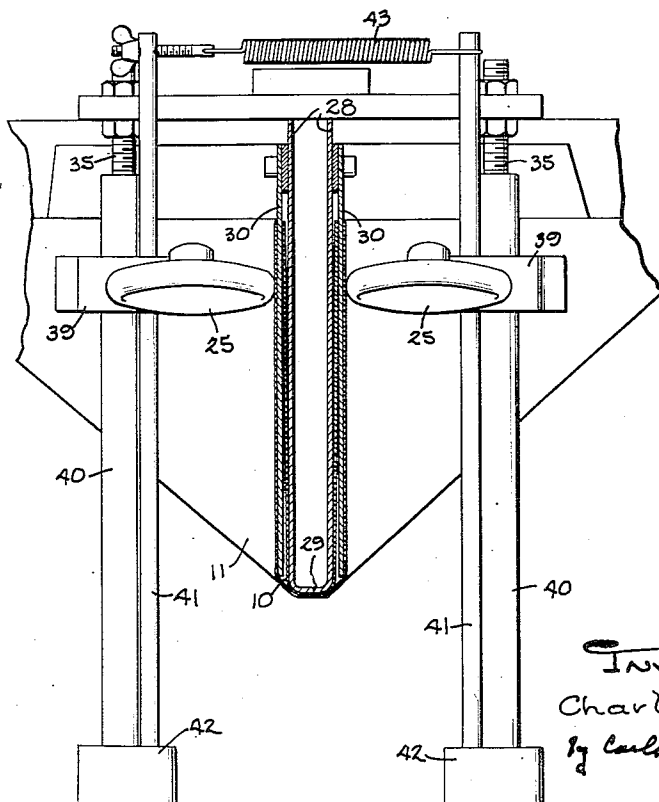

FIG. 3



INVENTOR
Charles B Harker
By Carlson, Pitzer, Hubbard & Wolfe
ATTORNEYS

Sept. 11, 1956

C. B. HARKER

2,762,273

FOLDING AND GUIDING MECHANISM FOR DOUBLE WALL BAG MACHINES

Filed Nov. 26, 1952

3 Sheets-Sheet 3

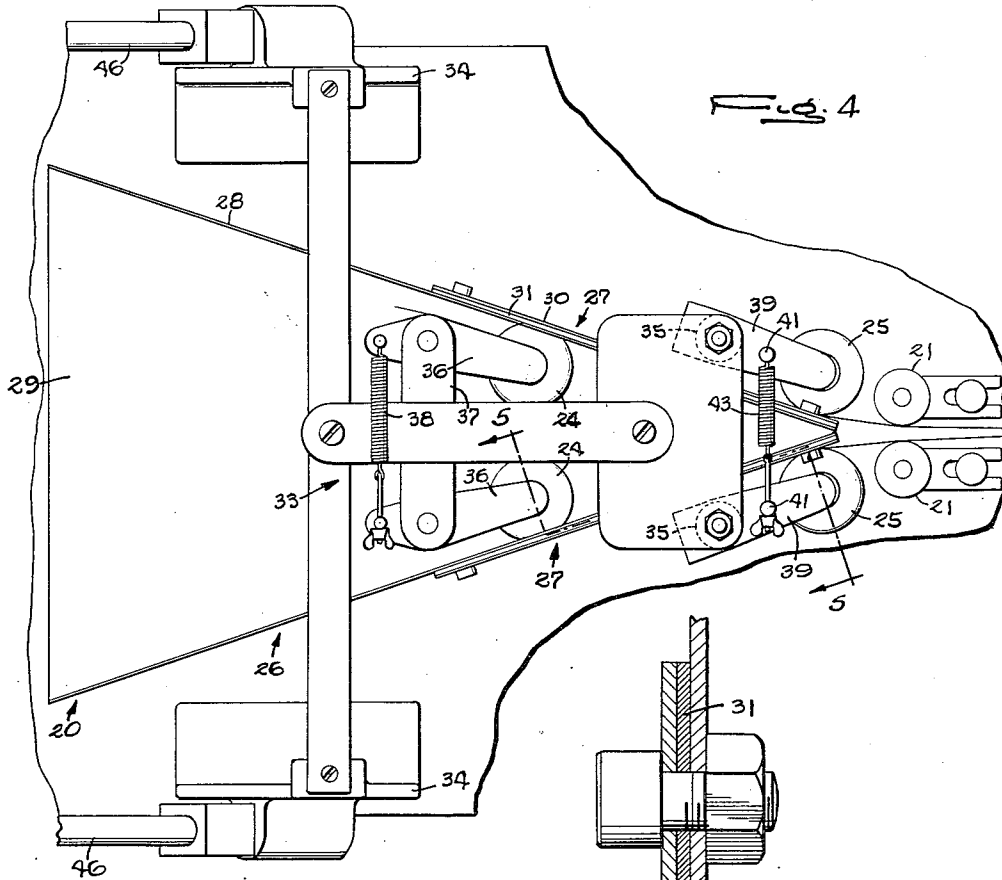
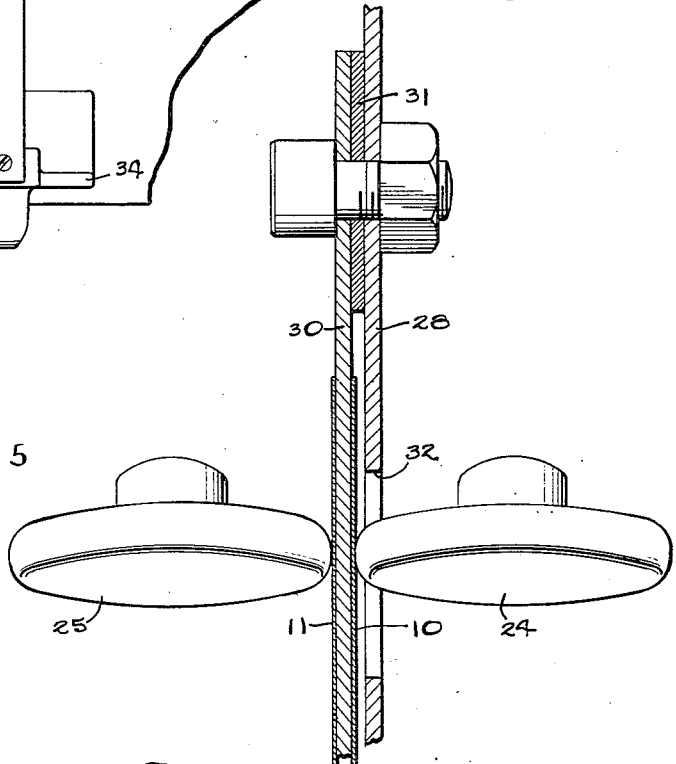

Fig. 4

Fig. 5



INVENTOR
Charles B. Harker
By Carlisle, Pitman, Hutton & Wolfe
ATTORNEYS

1

2,762,273

FOLDING AND GUIDING MECHANISM FOR DOUBLE WALL BAG MACHINES

Charles B. Harker, Rockford, Ill., assignor to Bartelt Engineering Company, Rockford, Ill., a corporation of Illinois

Application November 26, 1952, Serial No. 322,726

4 Claims. (Cl. 93—20)

This invention relates to machines for making double wall bags and, more particularly, to a machine in which the bags are formed in a series by folding two strips longitudinally, one inside the other, and then sealing the strips transversely at spaced intervals.

The general object is to provide in a machine of the above character a new and improved mechanism for folding the strips neatly with the two strips positioned accurately relative to each other.

A more detailed object is to control each strip individually as it is being folded by using separate sets of rollers to tension the strips about the folding mechanism.

Another object is to provide two formers, one in the path of each strip, so that each strip is folded separately thereby effecting a neater and more accurate fold.

The invention also resides in the novel means by which the strips are held out of contact with each other until they are ready to be sealed together so that the two strips may be guided individually into the bag forming path.

Other objects and advantages of the invention will become apparent from the following detailed description taken in connection with the accompanying drawings, in which

Figure 1 is a fragmentary side elevation with parts broken away of a bag making machine embodying the novel features of the present invention.

Fig. 2 is an enlarged fragmentary sectional view taken along the line 2—2 in Fig. 1.

Fig. 3 is an enlarged fragmentary sectional view taken along the line 3—3 in Fig. 1.

Fig. 4 is a plan view of the folding mechanism.

Fig. 5 is a sectional view taken along the line 5—5 in Fig. 4.

As shown in the drawings for the purpose of illustration, the invention is embodied in a machine for making double wall bags, that is, bags which have a liner inside the outer bag walls. Bags of this type may be made on a machine similar to the one shown in the copending application of Harold L. Bartelt, Serial No. 98,660, filed June 13, 1949, now Patent No. 2,649,674, to which reference may be had for further details. In general machines of this type form bags in a series by folding a strip 10 of liner material and a strip 11 of wall material longitudinally with the liner strip inside the fold of the wall strip and then sealing the two strips together transversely at equal intervals as indicated at 12.

In the present instance, the strips 10 and 11 are drawn off supply rolls 13 and 14, which are mounted on the frame 15 of the machine, by feed rollers 16 engaging the folded strips and driven intermittently through a suitable indexing mechanism 17 by a motor 18. From the supply rolls, the strips are threaded around a series of guide rollers, indicated generally at 19, and are advanced across a folding mechanism 20 which folds the strips. The folded strips pass between idler rollers 21 and then the seal 12 is formed during a dwell of the strips by heated shoes 22 operated from a camshaft 23 driven by the motor 18.

2

To effect a more accurate fold, the present invention contemplates the provision of a novel folding mechanism 20 in which the two strips 10 and 11 are held individually about the folding mechanism, and thereby are controlled individually, by separate sets of tensioning rollers 24 and 25. Preferably, the folding mechanism comprises two formers 26 and 27, one inside the other and each disposed in the path of one of the strips so that the strips are folded separately about individual formers and the outer former 27 serves as a common backing member for both sets of rollers 24 and 25. Thus, the rollers 24 are disposed within the fold and press the liner strip 10 against the inside of the former 27 while the rollers 25 hold the outer wall strip 11 against the outside of this former.

Herein, the inner former 26 comprises two triangular side plates 28 mounted on the frame with their apexes spaced apart laterally and located to be engaged first by the liner strip 10 as the latter is advanced by the feed rollers 16. The plates converge in the direction of advance of the strips meeting, as shown in Fig. 2, adjacent the idler rollers 21 and are joined together by a triangular bottom plate 29 which spans and is secured as by welding to the lower edges of the side plates 28. To form the outer former 27, a second set of generally triangular plates or members 30 are bolted to the outside of the plates 28 and held slightly away from the latter by spacers 31 so that the liner strip 10 may pass between the plates 28 and 30 as shown in Fig. 3.

Each of the rollers 24 and 25 is tilted upwardly as shown in Fig. 1 so that it tends to draw the side edge of the strip which it is engaging upwardly thereby drawing the strip around its former. The inside rollers 24 are disposed near the rear of the former 26 with one alongside each of the side plates 28 and each projecting through a hole 32 in the adjacent plate as shown in Fig. 3 so that they may engage the liner strip and press it against the side plate 30. The outer rollers 25 are mounted near the front of the folding mechanism 20 and cooperate with the plates 30 in a similar manner to hold the wall strip around the former 27.

To support the inner rollers 24, a framework 33 is mounted on the upper ends of posts 34 and 35 upstanding from the frame 15 and the rollers are journaled on the forward ends of arms 36 which are pivoted intermediate their ends on a transverse bar 37 of the framework. A contractile spring 38 acting between the rear ends of the arms 36 urges the rollers 24 outwardly against the inner surface of the liner strip 10. Each of the outer rollers 25 is journaled on an arm 39 which is clamped for vertical adjustment to a rotary sleeve 40 on the forward post 35. On each side of the folding mechanism 20 is a vertical rod 41 which is fixed to a collar 42 on the lower end of the corresponding sleeve 40 and projects up through a hole in the arm 39 and above the top of the plates 28 and 30. Acting between the upper ends of the rods 41 is a second contractile spring 43 urging the rollers inwardly against the wall strip 11.

With the foregoing arrangement, the liner strip 10 passes around the inner former 26 and between the side plates 28 and 30 while the outer wall strip 11 is advanced along the outer former 27 outside the plates 30. Due to the action of the springs 38 and 43, the inner rollers 24 are urged outwardly through the holes 32 in the plates 28 and hold the edge portions of the liner strip against the insides of the plates 30 and the outer rollers 25 are biased inwardly holding the wall strip against the outside of these same plates. As the feed rollers 16 draw the strips across the folding mechanism, the rollers, due to the upward tilt, tend to urge the edge portions of the strips upwardly thus tensioning each strip about its respective former so that the two strips are folded progressively, one inside the other.

In accordance with another aspect of the invention, the strips 10 and 11, as they are unwound from their respective supply rolls 13 and 14, are advanced along substantially independent paths until they are ready to be joined together by the sealing shoe 22 so that each strip may be guided individually and accurately into the bag forming path. To this end, the supply rolls are mounted independently and the guide rollers 19 are arranged in a novel manner to provide separate rollers for each strip. Thus, the supply roll 13 of liner material is carried on the outer end of a support 44 projecting rearwardly from the machine frame 15 and the liner strip 10 is threaded up around a roller 45 mounted on the outer ends of arms 46 which are fixed to and project rearwardly from the posts 34. From the roller 45, the liner strip passes down around a roller 47 journaled on arms 48 below the arms 46, then up around a roller 49 on the arms 46 inside the roller 45 and then across the former 26.

The supply roll 14 of wall material is mounted on a separate support 50 which is fixed to the frame 15 below the support 44 and the strip 11, as it is unwound from the roll, passes up along the inside of a roller 51 journaled on the upper support 44 and then up over a roller 52 on the arms 46 inside the roller 49. From the roller 52, the strip travels across the former 27. As shown in Fig. 1, the position of the rollers 49 and 52 is such that the two strips approach their respective formers along spaced paths which converge adjacent the forward end of the folding mechanism 20. At this point, the strips are ready to be joined together by the seal 12 after which they are advanced together through the bag making machine.

It will be observed that the strips 10 and 11 are folded separately about independent formers 26 and 27 and each is held about its respective former by a separate set of rollers. Thus, the two strips are folded individually and the resulting fold is neat and accurate. In addition, the strips are guided along separate paths by the guide rollers 19 and do not contact each other until just before they are sealed together. Although the strips may weave slightly before being folded, therefore, weaving of one will not affect the alinement of the other. Thus the strips when folded will be disposed properly relative to each other and the bags will be properly formed and neat in appearance.

I claim as my invention:

1. Mechanism for folding two strips of material, one inside the other, said mechanism comprising, two triangular plates spaced apart at their apexes and converging toward their bases, a pair of flat generally triangular backing members, one disposed alongside but spaced from the outer surface of each of said plates, a first pair of rollers disposed between said plates, each of said plates having a hole adjacent one of said rollers, a second pair of rollers disposed outside said backing members, and spring means urging said second rollers inwardly against the outer surfaces of said backing members and said sec-

ond rollers outwardly through said holes and against the inner surfaces of the backing members.

2. In a bag making machine, the combination of, mechanism for supporting and advancing longitudinally two strips of material disposed side by side, a first former disposed in the path of advance of a first one of said strips and operable to fold said first strip, a second former mounted exteriorly of said first former and in the path of the second strip to fold the latter whereby said first strip passes between said formers and said second strip passes on the outside of said second former, said first former having holes therein, a first set of rollers mounted inside said first former and projecting through said holes to hold said first strip against the inside wall of said second former and tension the strip around said first former, and a second set of rollers disposed exteriorly of said second former and acting to tension the second strip around the same.

3. In a bag making machine, the combination of, mechanism for supporting two strips of material disposed side by side and advancing the same endwise along predetermined paths, a folding device disposed in said paths and operable to fold said strips longitudinally one inside the other, a first set of rollers disposed inside the fold and engaging the inner strip to tension the latter around said folding device, and a second set of rollers mounted outside of the fold and engaging the outer strip to tension the same about said folding device, said folding device including rigid parts disposed outside said inner strip adjacent said first rollers to constitute a backing for the latter and rigid parts disposed adjacent said second rollers and inside the outer strip to provide a backing for said second rollers.

4. In a bag making machine, the combination of, a folding device, two flat backing members, one mounted at each side of said device, mechanism for supporting two strips of material disposed side by side and advancing the strips longitudinally across said device to fold the strips longitudinally with the edge portions of one strip passing across the inner sides of said members and the edge portions of the other strip passing across the outer sides of the members, a first set of rollers disposed between said members with each adjacent one member and each operable to press the inner strip against the adjacent member to hold the strip about said folding device, and a second set of rollers mounted exteriorly of said members and operable to press the outer strip against the members and hold that strip about said folding device.

References Cited in the file of this patent

UNITED STATES PATENTS

333,646	Lorenz	Jan. 5, 1886
1,943,549	Poppe	Jan. 16, 1934
1,949,879	Potdevin	Mar. 6, 1934
2,013,086	Baker	Sept. 3, 1935